



Schartec Move Series 3

Garage door opener installation and operation manual



600 / 600 Speed / 1000 / 1000 Speed / 1200



Scan me for the video instructions!

WARNING

Please read the manual carefully before you begin the installation and use of the opener. The installation of your new garage door opener must be performed by a competent expert or a specialist company. A competent person is, in accordance with EN 12635, considered a person who has appropriate training, qualified knowledge and practical experience in order to mount and maintain a door system properly and safely. The installation or repair without technical qualifications can lead to property damage, serious injury, and/or death.

Contents

| | |
|---|----|
| Important safety instructions | 2 |
| Warranty conditions | 4 |
| Before installation | 5 |
| Package contents | 6 |
| Installation | 7 |
| Programming | 10 |
| Connection of external controls and accessories | 12 |
| Manual unlocking | 13 |
| Technical data | 14 |
| Troubleshooting | 14 |
| Troubleshooting cont. | 15 |
| Declaration of Conformity | 16 |

Dear Customer

Thank you for choosing a quality product from the Schartec brand. Thanks to our unique quality management system, as well as continuous product development, Schartec garage door openers meet the highest standards of quality and comfort. We thank you for your trust and wish you much pleasure with your new Schartec garage door opener.

Declaration of Conformity (CE)

Schartec Move garage door openers meet the requirements of the applicable European and national directives. Conformity has been proven, the corresponding declarations, certificates, test reports and documents can be requested at info@schartec.co.uk. The Declaration of Conformity can also be found on page 17. The supplied radio system type T-11 (Art.No.ST801007) complies with Directive 2014/53/EU. The full text of the EU Declaration of Conformity is available at the following Internet address: www.schartec.co.uk

Important safety instructions

1. Intended use

The garage door opener is intended exclusively for the impulse operation of spring-balanced sectional and up-and-over doors in the private/non-commercial sector. Door systems that are located in the public area and only have a protective device, e.g. force limiter, may only be operated under supervision. The garage door opener is designed for operation in dry rooms.

2. Non-intended use

The garage door opener must not be used for purposes other than garage door opener automation. Continuous operation and use in commercial areas is not permitted. The opener must not be used on doors without fall protection.

3. Qualification of the fitter and installer

Only correct installation and maintenance by a competent/knowledgeable company or a competent/knowledgeable person in accordance with the instructions can ensure the safe and intended functioning of an installation. According to EN 12635, a competent person is a person who has suitable training, qualified knowledge and practical experience to correctly and safely assemble, inspect and maintain a garage door system.

4. Safety instructions for assembly, repair, maintenance and disassembly of the garage door system

DANGER!

Balancing springs are under high tension

Adjusting or loosening the balancing springs can cause serious injuries! For your own safety, only have work on the balancing springs of the door and, if necessary, maintenance and repair work carried out by an expert! Never attempt to replace, readjust, repair or relocate the balancing springs of the door or their brackets yourself. Also check the entire garage door system (joints, door bearings, cables, springs and fastening parts) for wear and possible damage. Check for existing rust, corrosion, and cracks. Faults in the garage door system or misaligned doors can result in serious injury! Do not use the garage door system if repair or adjustment work has to be carried out!

Mains voltage

In case of contact with the mains voltage, there is a risk of fatal electric shock. It is therefore essential that you observe the following instructions: Electrical connections may only be carried out by a qualified electrician. The on-site electrical installation must comply with the relevant protection regulations (230/240 V AC, 50/60 Hz). Disconnect the mains plug before carrying out any work on the opener.

WARNING!

Unsuitable mounting materials

The use of unsuitable mounting materials may result in the opener not being securely fastened and may come loose. The mounting materials supplied must be checked by the installer to ensure that they are suitable for the intended mounting location.

Danger to life due to hand cord

An entrained hand cord can lead to strangulation. Remove the hand cord during motor installation.

Risk of injury due to unintentional door movement

Incorrect installation or handling of the opener can trigger unintentional door movements and trap persons or objects. Follow all instructions contained in this manual. If control devices (such as push-buttons) are mounted incorrectly, unintentional door movements can be triggered, trapping persons or objects. Mount control devices at a height of at least 1.5 m (out of reach of children). Mount permanently installed control devices (such as push-buttons) within sight of the door, but away from moving parts.

Risk of injury due to unexpected door movement

Assembly, maintenance, repair and disassembly of the door system and garage door opener must be performed by qualified personnel. In the event of failure of the garage door opener, immediately commission an expert to inspect or repair it.

Safety instructions for installation

The qualified person must ensure that the applicable regulations for occupational safety and the regulations for the operation of electrical equipment are observed when carrying out the installation work. The national directives must be observed. Possible hazards in the sense of DIN EN 13241-1 are avoided by construction and assembly according to our specifications. The garage ceiling must be designed in such a way that safe mounting of the opener is ensured. If the ceiling is too high or too shallow, the opener must be fastened to additional struts.

CAUTION!

5. Safety instructions for commissioning and operation

Danger of crushing during rail mounting

When mounting the rail, there is a risk of fingers being crushed. Make sure that your fingers do not get caught between the profile ends.

Danger of crushing in the rail

Reaching into the rail during door travel can lead to fingers being crushed! Do not reach into the rail during door travel.

CAUTION!

Risk of injury from pull-cord

If you hang on to the pull-cord, you may fall and injure yourself. The opener may also break off and injure persons underneath, damage objects or be destroyed itself. Do not hang on the pull-cord with your body weight.

WARNING!

Risk of injury when the door is closing quickly

If the pull-cord is pulled while the door is open, there is a risk that the door may close quickly if the springs are weak, broken or defective or if there is insufficient weight compensation. Use the cord only when the door is closed.

Risk of injury during door movement

Injuries or damage can occur in the area of the door when it is moving. Make sure that no children are playing near the garage door. Make sure that there are no persons or objects in the area of movement of the door. If the door system only has a safety device, only operate the garage door opener when you can see the door's range of movement. Monitor the door movement until the door has reached the end position. Do not drive through or pass through door openings of remote-controlled door systems until the door has come to a standstill! Never remain standing under the open door. Instruct users Instruct all persons using the door system in the proper and safe operation of the garage door opener. Demonstrate and test the mechanical release and the safety return.

6. Safety instructions for using the remote control

WARNING!

Risk of injury from unintentional or accidental door movement

Pressing the button on the remote control can cause unintentional door movements and injure persons. Ensure that remote controls do not fall into the hands of children and are only used by persons who have been instructed in the operation of the remote-controlled garage door system! You must generally operate the remote control with visual contact to the door if it only has a safety device! Only drive through or pass through the door openings of remote-controlled door systems when the door has come to a standstill! Never remain standing under the opened door! Please note that a button on the remote control may be pressed accidentally (e.g. in a trouser pocket or handbag) and this may result in an unintentional door movement.

7. Safety devices

Safety-relevant functions and components such as the automatic force shut-off, as well as the use of external photocells, have been tested and meet the requirements of EN 12453 and EN 12445 standards.

WARNING!

Risk of injury due to non-functioning safety devices

To check the safety reverse, stop the door with both hands while it is closing. The door system must stop and initiate the safety reverse. Proceed in the same way while the door is opening. The door system must stop and the door must stop. In the event of a failure of the safety return, immediately commission an expert with the inspection or repair.

8. Inspection and maintenance

The garage door opener is maintenance-free. For your own safety, however, we recommend that you have the door system inspected and serviced by an expert in accordance with the manufacturer's instructions.

An inspection or a necessary repair may only be carried out by a qualified person. Please contact your supplier for this purpose. A visual inspection can be carried out by the opener. Check all safety and protective functions monthly. Any existing faults or defects must be rectified immediately.

Check the tension of the toothed belt every six months and adjust it if necessary. During the start-up and braking phase, the belt may briefly hang out of the rail profile. However, this effect does not have any technical consequences and does not adversely affect the function and service life of the opener.

Warranty conditions

Warranty

We are exempt from warranty and product liability if without our prior consent own structural changes are made or improper installations are carried out or arranged against our specified installation guidelines. Furthermore, we accept no responsibility for the accidental or careless operation of the opener, nor for the improper maintenance of the opener and accessories, nor for the improper maintenance of the door and its counterbalance. Batteries, light bulbs and LEDs are also excluded from warranty claims.

Duration of the warranty

In addition to the dealer's statutory warranty under the purchase contract, we provide the following warranty from the date of purchase:

- 3 years
- 2 years on radio and accessories

Claiming the warranty does not extend the warranty period. For replacement deliveries and repair work, the warranty period is six months, but at least the current warranty period.

Requirements

The warranty claim is only valid for the country in which the device was purchased. The goods must have been purchased through the sales channel specified by us. The warranty claim is only valid for damage to the subject matter of the contract itself. Reimbursement of expenses for removal and installation, inspection of corresponding parts, as well as claims for lost profit and damages are excluded from the warranty. The proof of purchase is valid as evidence for your warranty claim.

Performance

For the duration of the warranty, we will remedy all defects in the product that are demonstrably due to a material or manufacturing defect. We undertake, at our option, to replace the defective goods free of charge with defect-free goods, to repair or to compensate for a reduced value. Excluded are damages due to:

- improper installation and connection
- improper commissioning and operation
- external influences such as fire, water, abnormal environmental conditions
- mechanical damage due to accident, fall or impact
- negligent or willful destruction
- normal wear and tear or lack of maintenance
- repair by unqualified persons
- use of parts of foreign origin
- removal or obscuring of the serial number
- removing or cutting the power cord

Replaced parts become the property of the manufacturer

Before installation

1. Check door system

DANGER!

Balancing springs are under high tension. Adjusting or loosening the balancing springs can cause serious injuries! For your own safety, only have work on the balancing springs of the door and, if necessary, maintenance and repair work carried out by an expert!

Never attempt to replace, readjust, repair or relocate the balancing springs for the door or their brackets yourself. Also check the entire door system (joints, door bearings, cables, springs and fasteners) for wear and possible damage. Check for existing rust, corrosion, and cracks. Faults in the door system or misaligned doors can result in serious injury! Do not use the garage door system if repair or adjustment work must be carried out!

The construction of the opener is not designed for the operation of heavy-duty doors, i.e. doors that can no longer be opened or closed by hand or can only be opened or closed with difficulty. The door must be in a mechanically fault-free condition so that it can be easily operated by hand (EN12604). Raise the door approx. half of the opening travel and release it. The door should remain in this position and not move down or up. If the door does move in either direction, there is a risk that the balancing springs/weights are not properly adjusted or are defective. In this case, increased wear and malfunction of the garage door can be expected. Check whether the door can be opened and closed properly. Disable the mechanical locks of the door that are not required for operation with a garage door opener. This includes in particular the locking mechanisms of the door lock.

Switch to the picture section for assembly and commissioning. Refer to the relevant text section if indicated by a capitalized note for the text reference.

2. Required clearance

The clearance between the highest point at the door run and the ceiling must be at least 30 mm. If the clearance is less, the opener can be mounted behind the open door, provided there is enough space. In these cases, an extended door attachment must be used, which must be ordered separately. The necessary socket for the electrical connection should be mounted approx. 50 cm next to the opener head (see chapter Mains voltage). Check these dimensions!

Important note: The use of a photocell (available separately) is recommended as an additional safety device.

3. Emergency release

For garages without a second access, an emergency release is required for mechanical unlocking to prevent possible lockout in the event of a mains voltage failure. The emergency release is door-specific and must be ordered separately. Check the emergency unlocking device for proper functioning on a monthly basis.

Package contents

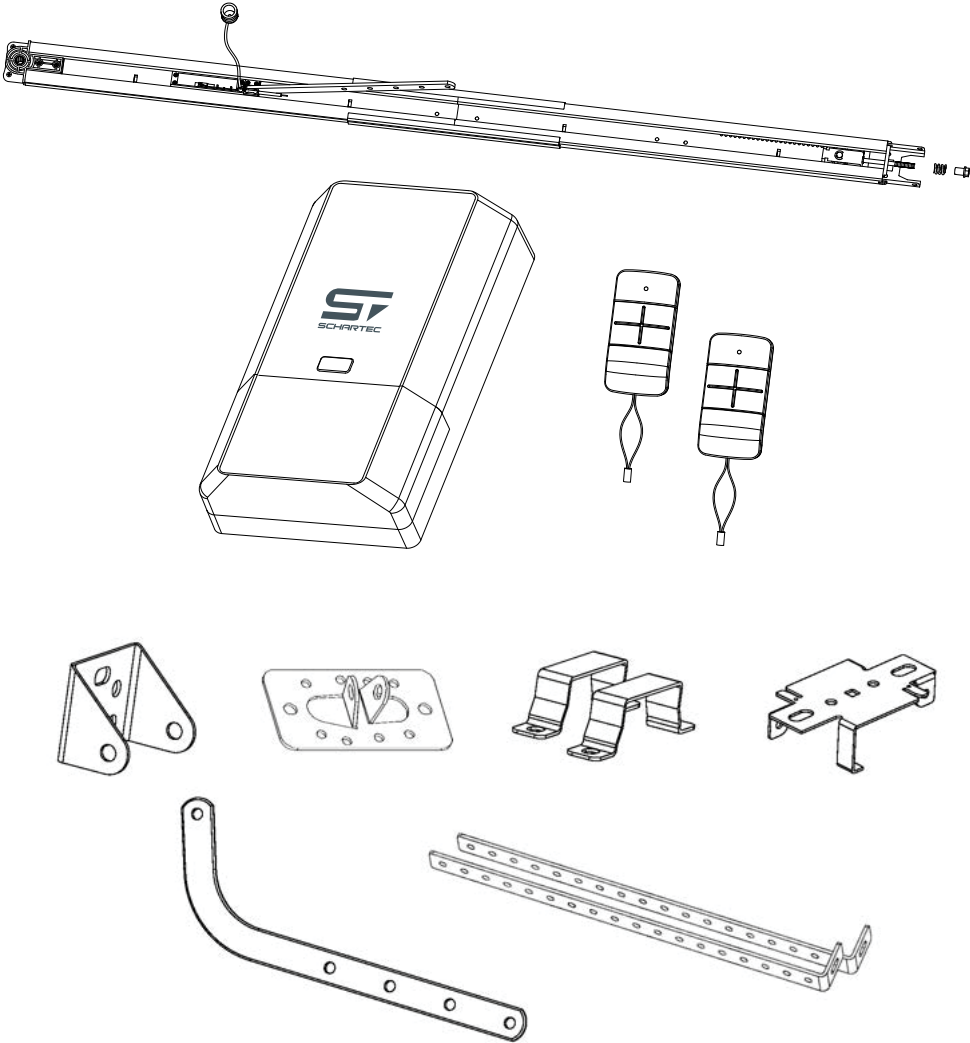

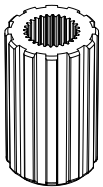
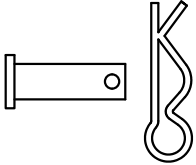
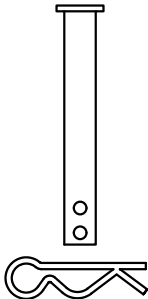
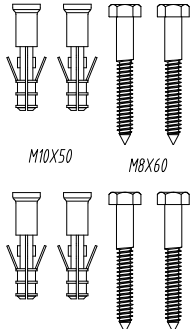
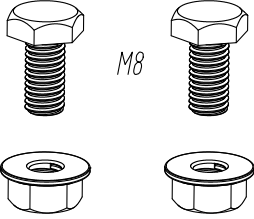
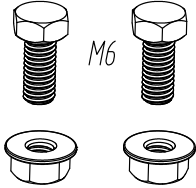
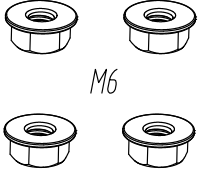
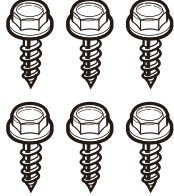
| | | | |
|--|--|---|---|
|  <p>A Motor Shaft Sleeve</p> |  <p>B for door bracket</p> |  <p>C for wall bracket</p> |  <p>M10X50 M8X60 G for mounting wall bracket</p> |
|  <p>M8 D for straight / bent arm</p> |  <p>M6 E for mounting Easy-Click bracket</p> |  <p>M6 F for U hanging bracket</p> |  <p>for door bracket installation</p> |

Installation

Precondition

Between the rails and the door a distance of 30 mm and maximum 400 mm is necessary to mount the opener correctly.

Fig. 1

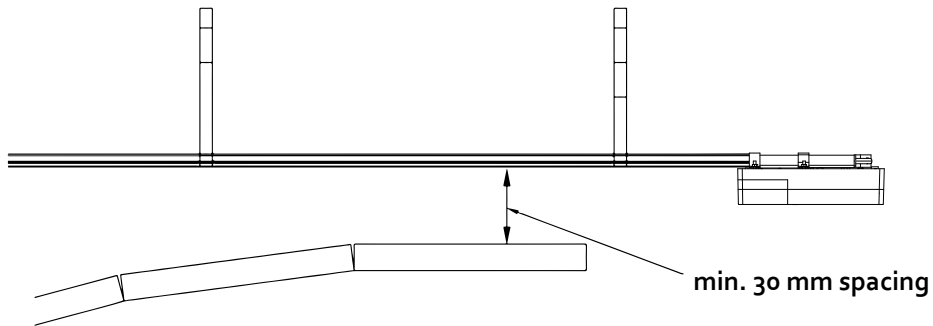

Assembling the rail

1. Pull the belt with the pulley out of the first rail section.

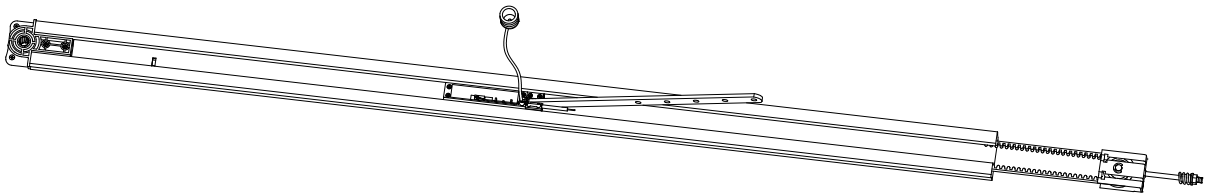

2. Push the pulley with the toothed belt into the second rail section. Then join the two rail sections with the connector.

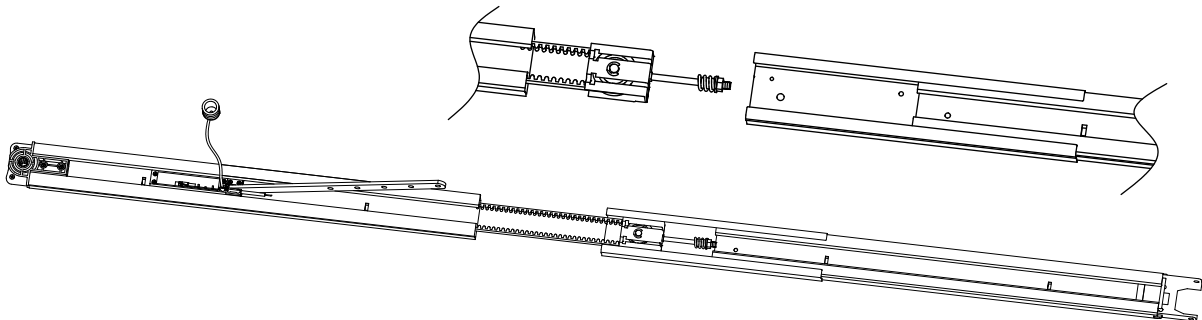

3. Pass the threaded rod through the hole and guide the spring, washer and nut onto the threaded rod as shown below. Before you tighten the nut now, check again if the belt is centered on the idlers. Tighten the nut until the spring is almost fully compressed as shown below. The rail is now fully assembled.

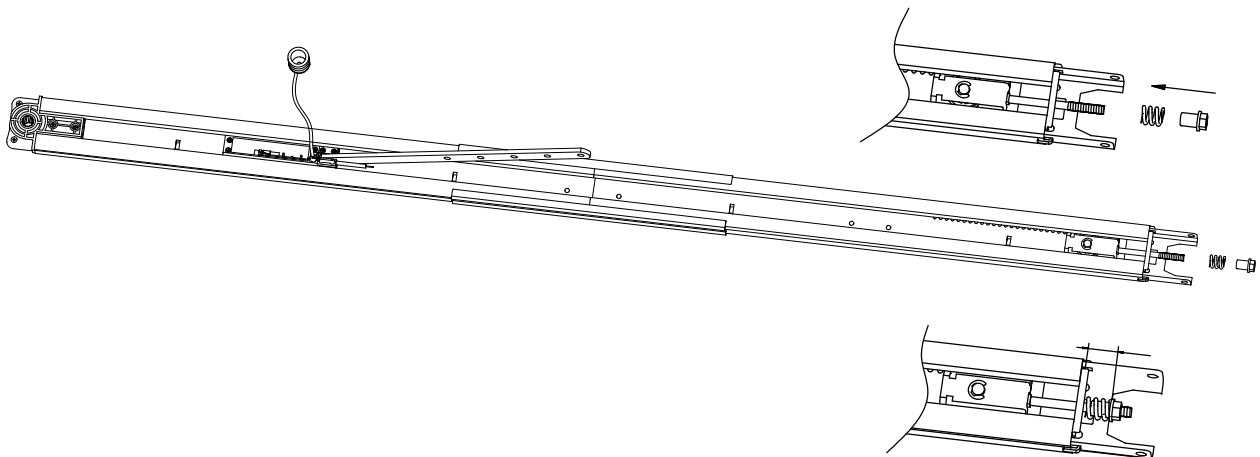

Fastening the door leaf bracket and wall bracket

Wall Bracket - Close the garage door and measure the width of the garage door at the top edge. Then mark the center. Now fasten the wall bracket 2-15 cm above the top edge of the garage door to the inside wall. (The distance depends on the local installation situation).

Door leaf bracket (figure similar) - Attach the door leaf bracket as close as possible to the upper edge of the door leaf.

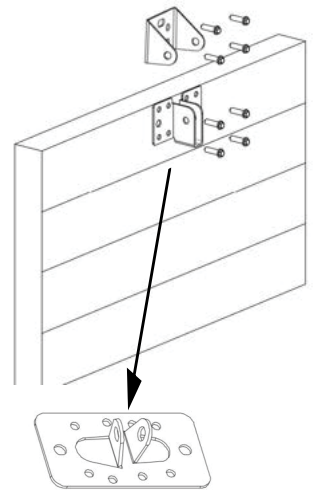

Installing the rail with the opener

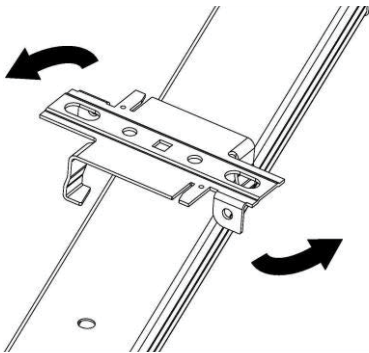
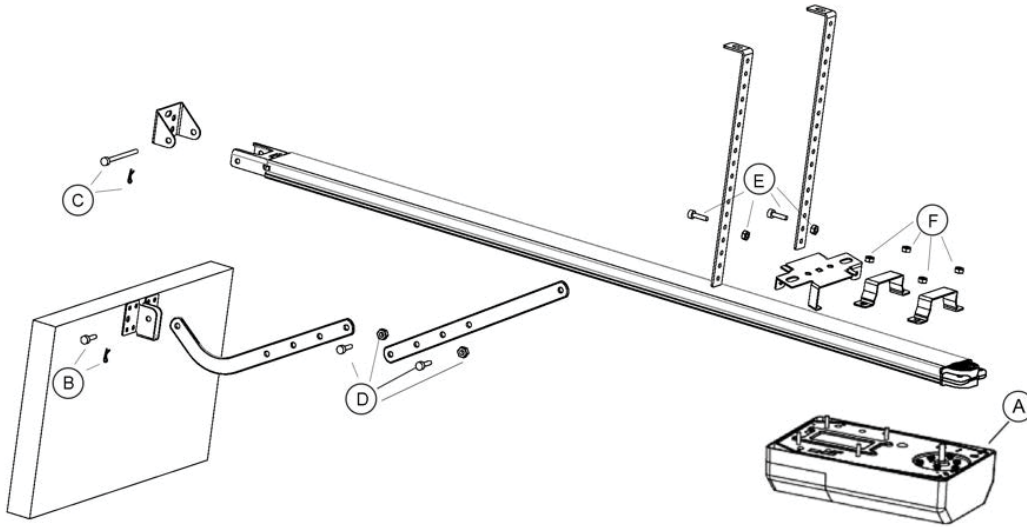

Step 1

Attach the opener to the rail, putting on the motor shaft sleeve (A) beforehand. Fasten using the two retaining brackets with the supplied 6 mm nuts (F).

Step 2

Place the rail with the opener centrally on the garage floor, with the motor side away from the garage door. Lift the front of the rail up to the wall bracket, slide the bolt through the holes in the bracket and rail, and then secure it with the cotter pin (C) provided.

Step 3

Position the Easy-Click bracket anywhere on the back of the rail (in the rear area). Rotate the Easy-Click bracket onto the rail and then bend down the two tabs on the side with pliers.

Step 4

Lift and support the opener (with a ladder or similar) in a centered position and position the rail at a horizontal level. **WARNING:** make sure that no children are near the garage door, opener, or support ladder. Failure to heed this warning may result in serious damage and injury.

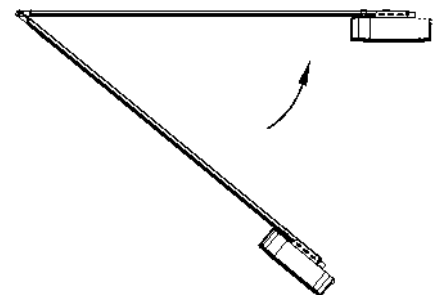
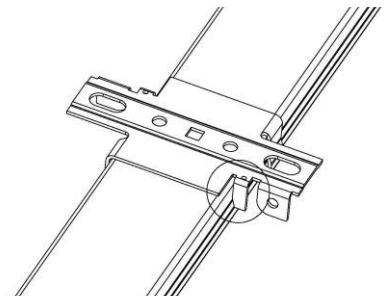

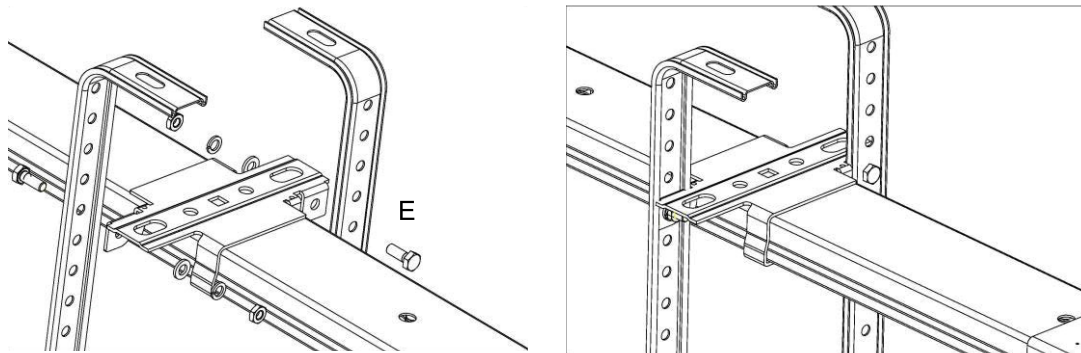

Step 5
Now connect the Easy-Click bracket to the two ceiling suspensions you have previously mounted on your garage ceiling using the supplied screws and nuts (E).

***Fixing screws and dowels for the ceiling hangers are not included in the package.**

Step 6
Now slide the carriage into the front part of the rail with the garage door closed. Connect the curved door arm to the straight connector of the door carriage using the supplied bolts and nuts (D). Using the bolt and cotter pin provided, attach the door follower to the door blade bracket (B) as shown to the right.

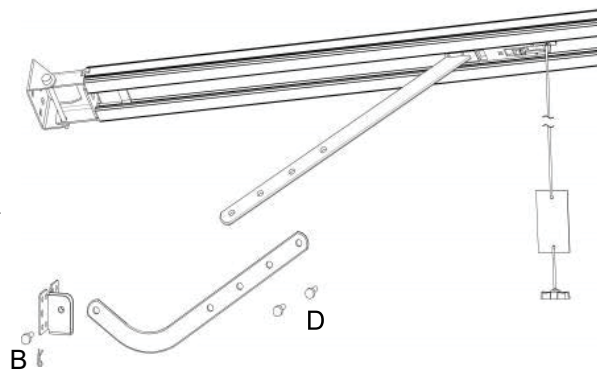

Step 7
Now lift the garage door until the carriage engages the toothed belt. Now the opener is ready to teach the end positions.

Remove the motor cover

To access the display for programming the door opener, you must remove the transparent cover by pushing it forward by hand (see figure below).

ATTENTION! When you plug the door opener into your grounded socket, it performs a self-test. The display shows the following sequence of symbols during this phase:

9-8-0-1 and counts down 9-8-7-6-5-4-3-2-1-0-U (or similar) immediately afterwards. After this, "U" is shown. The door opener is now ready for programming. If a "-" is present, the end positions are not programmed and must be programmed.

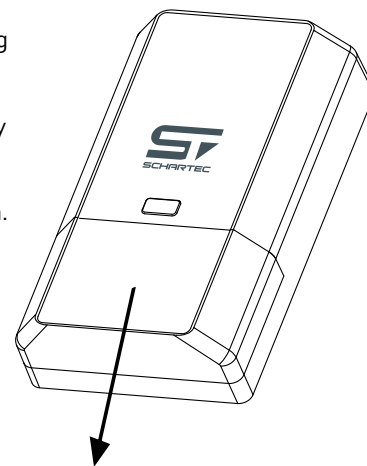

NOTICE - VERY IMPORTANT BEFORE SYSTEM LEARNING!

Ensure that the connector piece within the belt is properly connected to the trolley.

Manually open/close the door until the trolley "locks" into the belt. Very important to do this BEFORE system learning!!

Failing to do so will lead to the belt connector piece running "into" the motor head and the error E1 will show on the motor! Please ensure this step is completed BEFORE doing the system learning!

Programming

Programming the end positions

1. Press and hold the SET button until the number 1 appears on the display and release the button. The opener is now in programming mode.
2. Now press and hold the UP button until the door has reached the desired position 'open'. Note: Fine adjustment of the door position can be made by briefly tapping the UP/DOWN key.
3. Now press the SET key to confirm the position. The display will now show the number 2.
4. Next, press the DOWN key until the door reaches the desired door position "closed". For fine adjustments, briefly touch the DOWN/UP key.
5. Now press SET to confirm the closing position.

CAUTION: The garage door will now open and close to adjust and calibrate the end positions and the tension and compression forces. When finished, the display shows "u", the opener is ready for normal operation. If "-" is shown, the end positions have not been saved!

Programming the remote controls

Note: The remote controls included in the delivery are pre-programmed and do not need to be programmed. If not, please follow the instructions below.

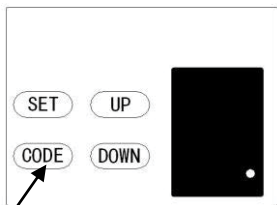

1. Press the CODE key. A dot appears in the corner of the display.
2. Now press once the button on the remote control you want to use. Now wait for 2 seconds, and press the same button on the remote control again for about 2 seconds.

The dot on the display will flash, then go off and return to the display screen with the "u" (normal operation). Repeat this procedure with the second remote control.

Deleting stored remote controls

Press and hold the CODE key until C appears on the display. All stored codes are now deleted.

Setting the force cut-off (menu 3)

ATTENTION: The force cut-off is already set automatically during the teach-in run. An adjustment via the menu is usually not necessary.

The forces predefined in the factory setting (value 2) are designed for trouble-free operation for standard garage doors intended for operation with the door opener. The forces exerted in the factory setting should generally be sufficient to fully open and close the garage door to be operated.

In the factory setting, the garage door opener meets the requirements for operating forces specified by law or in relevant standards (such as EN 13241-1, EN 12453, EN 60335-2-95) and thus the maximum permissible forces.

However, the forces used by the opener can also be increased or decreased (values 1-3), if required, by following the procedure described below.

Note:

This must be done, for example, if one of the end positions "Door Open" or "Door Closed" is not reached in the factory setting (value 2). In this case, the setting for the maximum force must be increased step by step until both end positions are reached, as described below.

Furthermore, it is possible that the running behavior or the door mechanics of the garage door deteriorate in the course of the operating time (e.g. due to a reduction in the spring tension). For safety reasons, it may then be necessary to adjust the forces, as otherwise manual operation of the door, which may be necessary to open or close the door, poses a safety risk (e.g. door falling down) to persons and property.

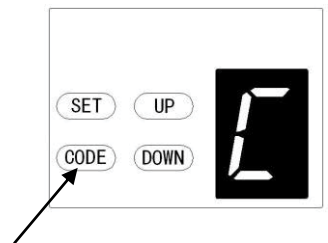
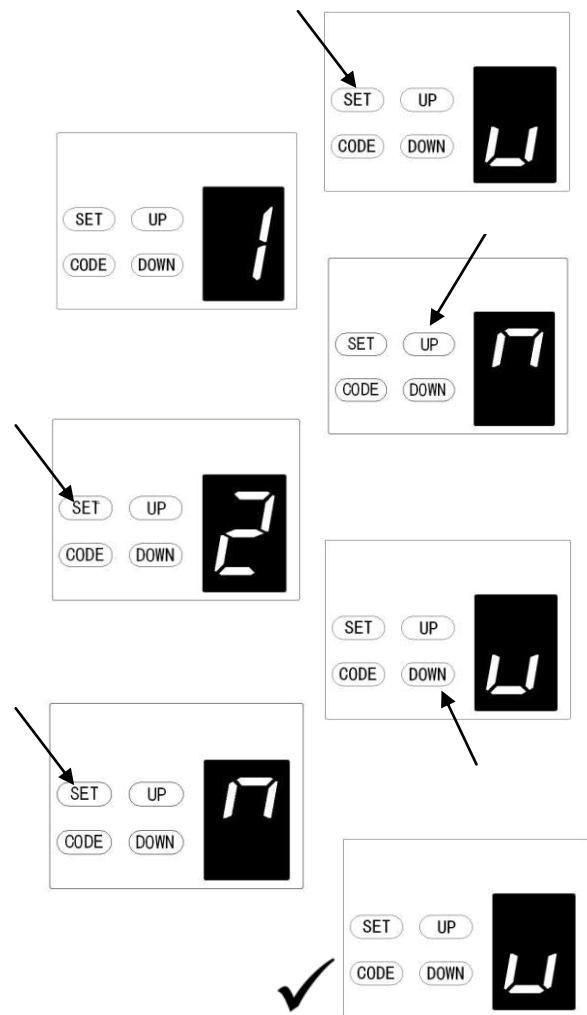

But

CAUTION:

An increased force setting value deviating from the factory setting (value 2) can lead to serious injuries for persons and animals, up to danger to life, as well as damage to property! An increased force setting value deviating from the factory setting increases the forces exerted by the garage door opener for the opening and closing movement of the door. If the factory setting is changed, there is a risk of serious personal injury or even danger to life, as well as a risk of damage to property, for example, if persons, animals or objects are trapped or crushed in the door area, since an increase in the force setting that deviates from the factory setting can lead to the maximum permissible force limit values mentioned above being exceeded. Therefore applies:

Note:

After each force setting (values 1-3) deviating from the factory setting (value 2), compliance with the force limit values required by law or in the relevant standards must be checked, accepted, measured and documented by a competent person in order to exclude the above-mentioned hazards to life and limb and damage to property.

1. Press and hold the SET key until the number 3 appears on the display and then release the key. The opener is now in the force cut-off menu and displays the number 2 (factory setting of force cut-off).
2. Press the UP key to increase the force for cutoff or the DOWN key to decrease the force for cutoff. The maximum force is 3 and the minimum force is 1.
3. Press SET to confirm the settings

Note: The factory setting of the force cut-off is 2.

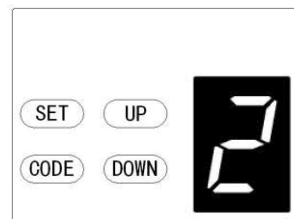
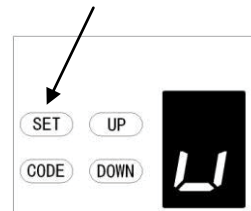

Increase force cut-off

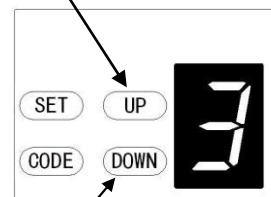

Decrease force cut-off

Automatic close

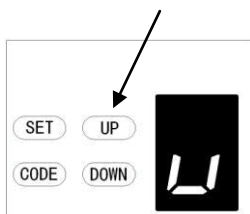

Automatic closing activated



Automatic closing deactivated

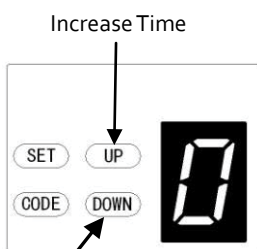

Decrease Time

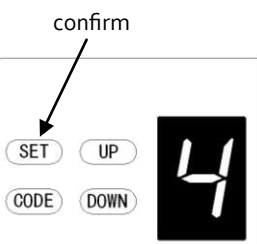

Note: For safety reasons, the connection of a photocell is required to use the automatic close (automatic close is not possible without a photocell).

1. Press and hold the UP key until an O appears on the display. Now press the UP key to set the automatic close in minutes.
2. Press UP to increase the time or DOWN to decrease the time. The maximum possible time is 9 minutes. To deactivate the automatic close, set 0 on the display.
3. Press the SET key to confirm the setting.

!! Automatic closing is only permissible together with the operation of a photocell!!

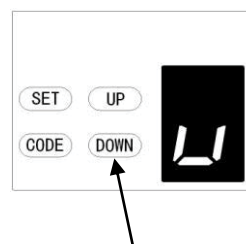

Photocell activated



Photocell as safety device

Note: Make sure that the photocell is properly installed and connected to the NC contacts of the terminal strip (Fig. 15).

Please also note that the photocell function must be deactivated if no photocell is installed. Otherwise, the door will not close.



Photocell deactivated

1. Press and hold the DOWN key until the number 11 appears on the display. To activate the photocell function, press the UP key again, the display shows an H (activated) or press DOWN to deactivate the photocell function (display 11).
2. Press SET to confirm the setting.

Partial opening/ventilation position

1. Press and hold the SET key until 5 appears on the display and then release. The display now shows the number 0 (zero - the factory setting for partial opening).
2. Now press the UP key to activate and increase the partial opening. Press the DOWN key to decrease or deactivate the partial opening (value 0-9).

- 0 = partial opening deactivated
- 1 = partial opening 5 cm (lowest)
- 2 = partial opening 15 cm
- 3 = partial opening 30 cm
- 4 = partial opening 60 cm
- 5 = partial opening 90 cm
- 6 = partial opening 120 cm
- 7 = partial opening 150 cm
- 8 = partial opening 180 cm
- 9 = Partial opening 210 cm (highest)

3. Then press the SET key to confirm.

ATTENTION!

- When partial opening is activated, key 4 (bottom right) of the remote control is programmed for partial opening.
- Only the maximum possible partial opening values are displayed in the menu, depending on the complete opening height. For example, the value 9 is only displayed if max. opening of the door is higher than 210 cm.

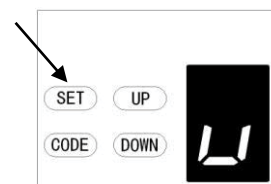
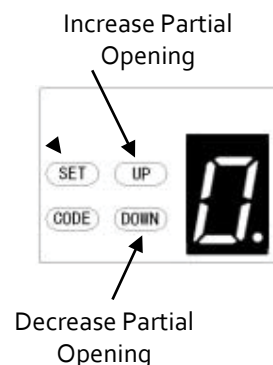
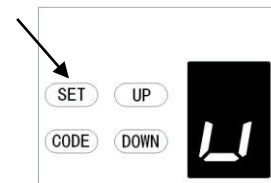

Disable power saving mode

(effective only motors that have "Standby: ≤0,8 Watt" listed on the product label.)

WARNING! Due to changes introduced by Commission Regulation (EU) 2023/826, standby power consumption must now remain below 1 watt. As a result, the external 12–35V outputs are no longer active while in standby mode. To use these outputs, standby mode must be disabled—this will render the device non-compliant with EU Ecodesign regulations. Proceed only if you fully understand the implications.

After 3 minutes of standby, the LED will display a '!', indicating that the motor has entered low-power mode.
To deactivate this mode, please follow these steps:

1. Press and hold the SET button until 'b' is displayed.
2. Press UP until '1' is shown on the display.
3. Press SET to confirm. The low-power function is now disabled.

To reactivate the low-power mode:

1. Press and hold the SET button until 'b' is displayed.
2. Press DOWN until '0' is shown on the display.
3. Press SET to confirm. The low-power function is reactivated.

Connection of external controls and accessories

1. **The O/S/C connection:** Connect an external push-button or key-switch to the door opener.
2. **Photocell Connection:** Connecting a photocell increases safety when operating your garage door opener. **IMPORTANT!** Remove the jumper in the terminal strip if you use a photocell. And be sure to check the function before use.
3. **Warning light connection:** This connection is suitable for the following warning lights: 24-35V DC, max. 12 Watt, max. 500 mA.
4. **Wicket door contact connection:** This function prevents the garage door from opening when the wicket door in the door leaf is open, thus preventing damage to the door. **IMPORTANT!** Remove the jumper in the terminal strip when using a wicket door contact. And be sure to check the function before use.

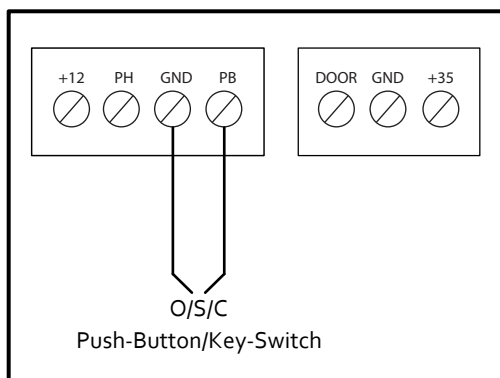

Fig. 14

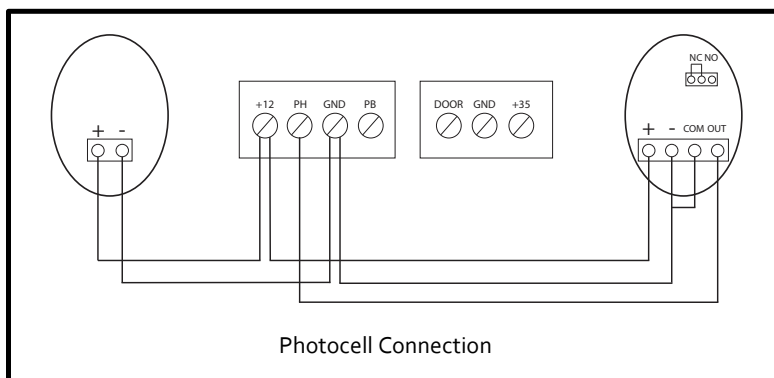

Fig. 15

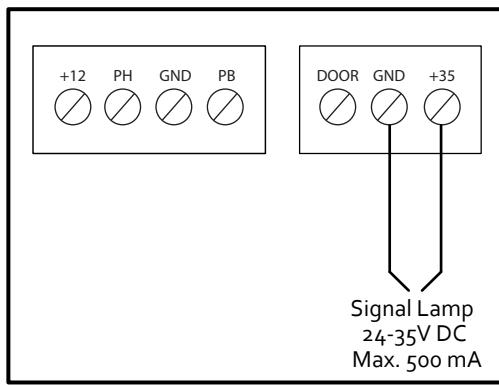

Fig. 16

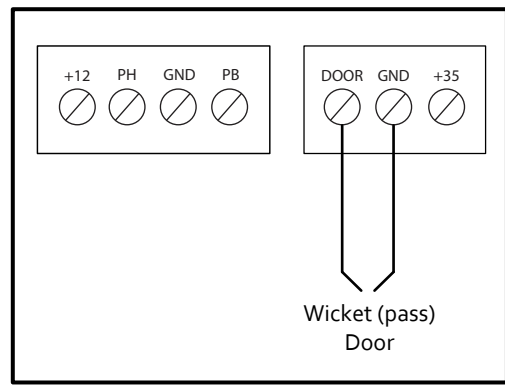

Fig. 17

Reminder:

If you are connecting a device to the 12–35V output (e.g. wireless receiver, keypad, etc.), please note that this output is disabled while the system is in standby mode to comply with EU Regulation (EU) 2023/826. To supply power to connected devices, you must deactivate the low standby power function. Please be aware that doing so will render the device non-compliant with current EU Ecodesign regulations. NOTE: photocells/signal lamps are not affected by this and will always receive power when the garage door opener is opening/closing.

Manual unlocking

Fastening the warning sign

Attach the anti-trap warning sign permanently to a conspicuous, cleaned and degreased location, for example near the permanently installed button for operating the opener.

The garage door opener is equipped with a manual release. This allows the garage door to be opened and closed manually when the cable is pulled down. To unlock, simply pull the cord. To re-engage, simply open the door opener automatically or move the door by hand until the carriage is re-engaged with the chain/timing belt.

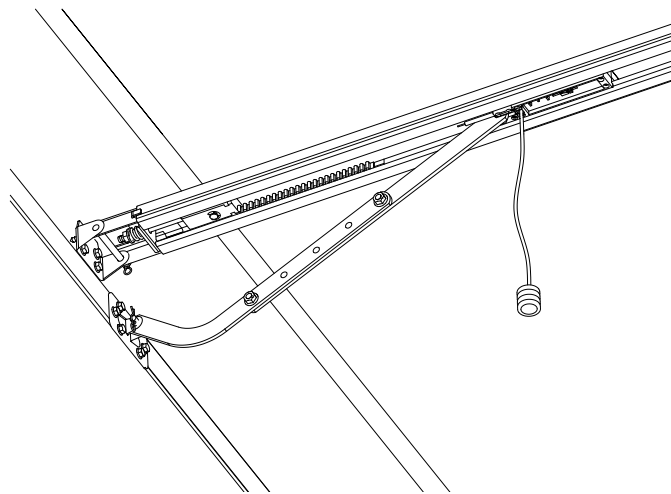

If you do not have a second access to the garage, an external emergency release (not included) is recommended to create an emergency access to the garage.

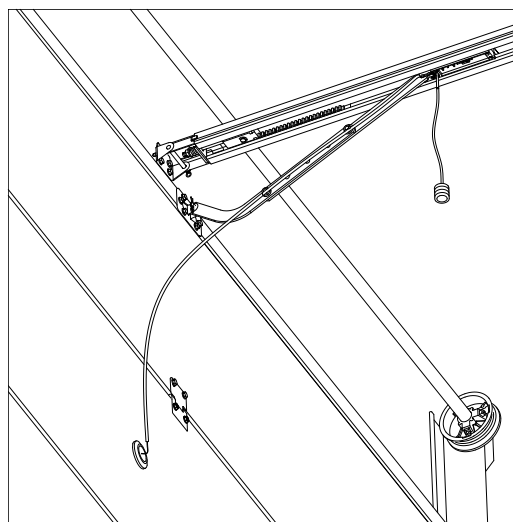

Technical Data

| | Move 600 | Move 1000 | Move 1200 | Move 600-Speed | Move 1000-Speed |
|----------------------|--|---|---|---|---|
| Power supply | 230 - 240V, 50-60 Hz | | | | |
| Max. tractive force | 600 N | 1000 N | 1200 N | 600 N | 1000 N |
| Max. door area | 10 m ² | 14 m ² | 16 m ² | 10 m ² | 14 m ² |
| Max. door weight | 100 kg | 140 kg | 160kg | 80 kg | 100 kg |
| Max. door height | 2400 - 3500 mm | | | | |
| Max. door width | max. 5000 mm/ max. 3500 mm for up-and-over wooden doors | max. 5500 mm/ max. 5000 mm for up-and-over wooden doors | max. 6000 mm/ max. 5000 mm for up-and-over wooden doors | max. 5000 mm/ max. 3500 mm for up-and-over wooden doors | max. 5500 mm/ max. 5000 mm for up-and-over wooden doors |
| Opening speed | 160mm / Sec | 160mm / Sec | 140mm / Sec | 200mm / Sec | 200mm / Sec |
| Power consumption | 200W | 245W | 260W | 200W | 245W |
| End position setting | Electrical | | | | |
| Transformer | Overvoltage protection technology | | | | |
| Radio frequency | 433.92 MHz | | | | |
| Coding | Rolling Code | | | | |
| Storage capacity | 20 codes | | | | |
| Working temperature | -20°C - +40°C | | | | |
| Safety devices | Soft start & Soft stop, photocell possible, warning light possible | | | | |
| Protection class | IP20 | | | | |

Troubleshooting

| Error Message | Possible Cause | Troubleshooting |
|--|--|--|
| No response from the garage door opener. | <ol style="list-style-type: none"> There is no power. Plug not inserted. | <ol style="list-style-type: none"> Check the voltage at the socket of the door opener. Carefully open the cover of the motor and check whether all cables are connected. |
| System learning will not start. | Photocell connected incorrectly or is not recognized by the motor. | <ol style="list-style-type: none"> Check the connection of the photocell. Adjust the photocell correctly. |
| Automatic closing cannot be set. | Photocell not connected. | Connect the photocell. This function is only possible with a connected photocell. |
| Opener opens and closes by itself. | Interference pulse / mounting next to the power line. | The motor must not be installed in the immediate vicinity of a power line (electrostatic charging). |
| Opener does not work. | End position open or closed set incorrectly. | Reset the end positions as described in the instructions. |
| Garage door only opens. Garage door does not close. | When using a photocell or when activating the photocell function without a connected photocell. | <ol style="list-style-type: none"> Check the photocell and make sure that no obstacle interferes with it. Deactivate the photocell function if no photocell is installed. To do this, follow the instructions. |
| Garage door automatically moves back 15-40 cm instead of closing completely. | Automatic safety return. Because of an old and incorrectly set garage door. Door not balanced or springs old, weak or defective. | <ol style="list-style-type: none"> Check the springs in every door position. Reset the end positions. Increase the power for automatic reversal. |
| Remote control does not work. | <ol style="list-style-type: none"> Battery is empty. Interference source in the area. | <ol style="list-style-type: none"> Replace the battery. Remove all sources of interference in the area (e.g. baby monitors, etc.). |

Troubleshooting cont.

| | | |
|---|---|---|
| Remote controls cannot be coded. | <ol style="list-style-type: none"> 1. Memory is full. 2. New remote control is not compatible with the door opener. | <ol style="list-style-type: none"> 1. Clear the remote control memory; recode all remote controls. 2. Use only original remote controls. |
| Display shows E1. Opener does not work. | <ol style="list-style-type: none"> 1. The belt connection for the trolley has run into the motor head. 2. No signal is recognized at the main hall sensor. | <ol style="list-style-type: none"> 1. Ensure that the connector piece within the belt is properly connected to the trolley. Manually open/close the door until the trolley "locks" into the belt. Very important to do this BEFORE system learning!! 2. Check the connection between the main hall sensor and the PCBA. 3. Call or write to your Schartec retailer for additional assistance. |
| Display shows E2. Opener does not work. | No signal is detected on the sub-hall sensor. | <ol style="list-style-type: none"> 1. Check the connection between the sub-hall sensor and the PCBA. 2. Call or write to your Schartec retailer for additional assistance. |
| Display shows E3. Opener does not work. | The count of the sub-hall sensor is faster than the count of the main hall sensor. | Learn the end positions again. |
| Display shows E4. Opener does not work. | <ol style="list-style-type: none"> 1. Wicket (pass) door is open. 2. Terminal block is not inserted. 3. Terminal block inserted correctly. | <ol style="list-style-type: none"> 1. Close the wicket (pass) door. 2. Plug the terminal block back in. Can possibly come loose during transport. 3. A bridge between GND and Door has been removed and needs to be replaced. |
| Display shows E6. Opener reverses when operating. | Obstacle in the door closing area. | Check and remove obstacle. |
| Display shows H. Opener does not work. | Opener overheated. | <ol style="list-style-type: none"> 1. Remove the opener from the power supply. 2. Contact your Schartec retailer. |



Declaration of Conformity

in accordance with the EC Machinery Directive 2006/42 /
EC, Appendix II, Part 1A

Schartec

a trademark from bau-shop-24 GmbH
Fritz-Müller-Strasse 115
73730 Esslingen, Germany

Importer for Great Britain:

Wilson Automation and Home Solutions Ltd.
Unit 8 The Gateway, Old Hall Road
Bromborough, CH62 3NX
United Kingdom

hereby declares that the door operators
Move 600/ 600 Speed/ 1000/ 1000 Speed/ 1200

were developed, constructed, and produced in agreement with the

- Machinery Guidelines 2006/42/EG
- Low-Voltage Directive 2014/35/EU
- Directive for Electromagnetic Compliance 2014/30/EU
- RoHS Guideline 2011/65/EU

The following standards were used:

- | | |
|--------------------------------|---|
| - EN 60335-1, where applicable | (Safety of elec. devices/openers for doors) |
| - EN 61000-6-3 | (Electromagnetic compatability) |
| - EN 61000-6-2 | (Electromagnetic compatability) |
| - EN 12453:2000 Paragraph 5.2 | (Usage safety of power-operated doors) |
| - EN 60335-1:2012 | (Safety of electronic devices) |
| - EN 60335-2-95:2015 | (Safety of electronic devices) |
| - EN ISO 13849-1:2008 | (Safety of machine controls) |

The following requirements of the Machinery Guideline 2006/42/EG were adhered to:

1.1.2, 1.1.3, 1.1.5, 1.2.1, 1.2.2, 1.2.3, 1.2.4, 1.2.6, 1.3.2, 1.3.4, 1.3.7, 1.5.1, 1.5.4, 1.5.6, 1.5.14,
1.6.1, 1.6.2, 1.6.3, 1.7.1, 1.7.3, 1.7.4

The corresponding technical documents will be transmitted electronically at the request of the agencies.

The incomplete machine is only specified for installation in a garage door system, in order thereby to create a complete machine according to the Machinery Guideline 2006/42/EG. The garage door system may first be in operation when it corresponds to the above-mentioned guidelines. If in doubt, a specialist company must be commissioned.

Esslingen, 29.02.2020

bau-shop-24 GmbH
Thomas Scharpf (CEO)



BAU-SHOP-24 GmbH
Fritz-Müller-Str. 115
73730 Esslingen
www.bau-shop-24.de
Tel. 0711-94571477 info@torshop-24.de
